

# W24As

2-way bi-amplified active loudspeaker system

**Montarbo**  
Made in Italy



Designed to provide maximum definition, cleanness and high sound pressure levels, the W24As bi-amplified loudspeaker system ensures outstanding sound performance in the most critical sound reinforcement applications.

Suitable for both indoor and outdoor use, its construction details and incredible versatility make this system ideal both for sound engineers and musicians. In spite of its compact size and light weight, W24As boasts all the features of much bulkier and heavier systems.

## FEATURES

- Typical features of much bulkier, heavier systems: high sound pressure levels, response extended to the extremes of the range, very low distortion, cleanness of the medium range, high dynamics.
- 2 class AB MosFet power amplifiers deliver a total output power of 1050 W (LF 800 W, HF 250 W).
- 134 dB max SPL.
- 2 x 12" woofers, 3" voice coil, with lightweight neodymium magnet assemblies.
- 2" neodymium compression driver - with titanium diaphragm and a 3" voice coil.
- 60° x 40° constant directivity horn.
- Trapezoidal cabinet, reinforced with internal steel braces, made from high grade phenyl-glued multiply birch and finished with highly resistant antiscratch polyurethane black paint.
- W24As may be flown using industry standard flying hardware. It embodies on both sides slide guides for standard anchor rings to allow the loudspeaker suspension. On its rear side there are two recessed rings for tilt adjustment of the suspended speaker.
- Stand adapter; ergonomically designed side handles for easy transportation and set-up.
- Neutrik PowerCon® AC mains connectors.

## APPLICATIONS

- Suitable for the most demanding professional requirements in the most diverse situations, for both indoor and outdoor use.
- Stadiums, arenas
- Concert halls
- Medium-to-large theatres
- Medium-to-large night clubs
- Large-scale events

# W24As

2-way bi-amplified active loudspeaker system

**Montarbo**  
Made in Italy



## ARCHITECTURE

- The bass section utilizes two 12" (3" voice coil) high efficiency woofers, with lightweight neodymium magnet assemblies, capable of delivering an exceptionally accurate and detailed high-impact sound.

The mid-high section is equipped with a 2" neodymium compression driver - with titanium diaphragm and a 3" voice coil - coupled to a constant directivity horn (dispersion 60° V x 40° H).

The whole mid-high range is reproduced with excellent definition.

Vocal harmonics and instruments are rendered with plenty of punch and precision, and remain tightly focused even at great distances.

- The built-in electronics includes:

- 2, class AB, Mosfet amplifiers, each one fitted with our exclusive loudspeaker protections and a soft-start circuit to reduce the peak current drain at switch-on. The two on-board power amplifiers deliver a total output power of 1050 W divided into 800 W for the bass section and 250 W for the mid/high section.

- 2 active dynamic processors, which optimise the specific features of each component and provide direct control of the operation of the systems, ensuring a constantly flat frequency response. They feature independent time constants (and operating thresholds that are sensitive to line voltage) and limit any excessive voice coil movement under the most demanding operating conditions. Unimpeded operation is guaranteed even when the system is subjected to extreme line voltage excursions.

- a high slope active electronic crossover (24dB/oct. Linkwitz-Riley) guaranteeing phase coherency and perfect overlapping of acoustic emissions of the transducers in the crossover region.

- the output stages are cooled by an improved forced air heat exchanger, equipped with a temperature-controlled, low-noise, fan that ensures safe and cool operation under any operating conditions.

- The rear control and connection panel is fitted with: balanced XLR input and output, master volume control and mid-high level control, mains Neutrik PowerCon® connector which guarantees a reliable vibration-proof, contact.

- The trapezoidal cabinet, reinforced with internal steel braces, is made from high grade phenyl-glued multiply birch and finished with highly resistant antiscratch polyurethane black paint.

It is fitted with ergonomically designed side handles for easy transportation and set-up, sturdy steel protection grille and stand adapter.

The cabinet embodies on both sides slide guides for standard anchor rings to allow the loudspeaker suspension. On its rear side there are two recessed rings for tilt adjustment of the suspended speaker.

# W24As

2-way bi-amplified active loudspeaker system

**Montarbo**  
Made in Italy

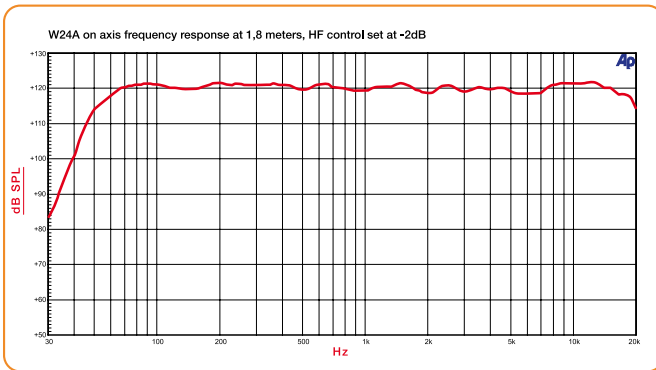

## TECHNICAL SPECIFICATIONS

Enclosure	2-way; vented; flyable
Frequency response	50 Hz ÷ 20 kHz ±3dB
Sensitivity	103 dB SPL @ 1W/1m on axis
Max. SPL	134 dB
Max. power	1050 W (LF 800 + HF 250)

• Components	custom designed
- bass frequencies	2 x 12" neodymium magnet, high efficiency woofers (3" voice coil)
- mid/high frequencies	2" neodymium driver (3" voice coil, titanium diaphragm) constant directivity horn (60°H x 40°V)
Impedance	4 ohms (bass) / 8 ohms (mid/high)
Frequency response	bass frequencies: 50 Hz ÷ 1000 Hz mid/high frequencies: 1000 Hz ÷ 20 kHz

• Active electronic x-over	24 dB/oct Linkwitz-Riley filter
Crossover frequency	1000 Hz

• Built-in amplifiers	2 MosFet, class AB, dedicated power units with 2 independent dynamic processors and 'soft start' circuit; forced air heat exchanger
-----------------------	---

Max. output power	1050 W
- LF	800 W (4 ohms / 0,1% THD)
- HF	250 W (8 ohms / 0,1% THD)

Frequency response	35 Hz ÷ 25 kHz +0/-1dB
Input impedance	10 kohm (balanced)
Input sensitivity	0 dBu (775mV)
Noise referred to input	- 108 dB (A weighted)

• Connections	balanced 3-pin XLR input and output PowerCon® connector for mains power (input + link)
---------------	---

• Controls	master volume control mid-high level control
------------	---

\* W24As is CB certified

## PHYSICAL SPECIFICATIONS

• Construction	trapezoid; birch multiply; antiscratch polyurethane paint; powder coated steel protection grille
----------------	--

• Fittings	speaker stand adaptor; carrying handles; industry standard flying hardware: slide guides for standard anchor rings + recessed rings for tilt adjustment of the suspended speaker
------------	---

• Dimensions / Weight	W 41,4 x H 94,3 x D 36,8 cm / 42,5 kg
-----------------------	---------------------------------------

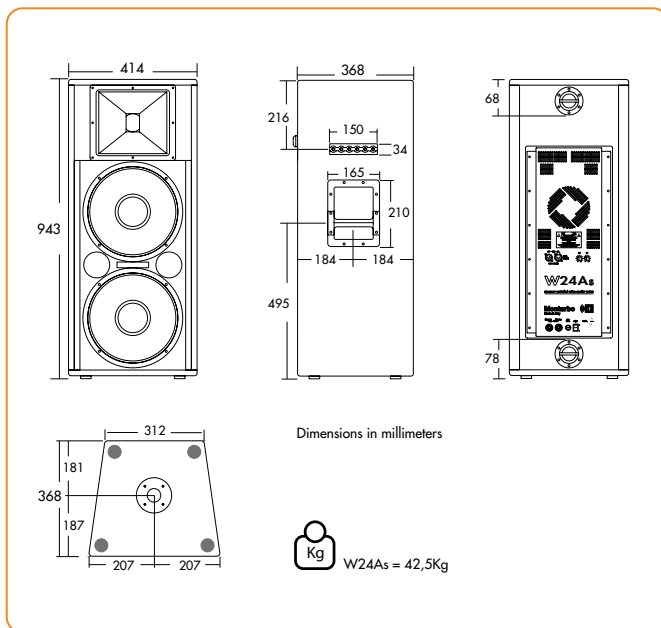

PRO - DATA SHEET