



WIDE 153 is a 2-way active bi-amplified speaker system with a versatility that allows for the maximum freedom of use.

Its user-programmable control system, based on the Montarbo DSP, and its small sized cabinet, make this system the perfect choice for professional and semi-professional users in any kind of venue.

WIDE 153 incorporates all the electronics needed to process and power the whole system. It is equipped with two class-D amplifiers (with switching-mode power supplies) managed by the Montarbo DSP loudspeaker processor (56 bit, 180 MHz, 24 bit converters) which provides filtering, equalization, delay, limiting and diagnostic functions. This DSP utilizes an advanced algorithm for the real time control of both the power output and the temperature (both internal and external) of the amplifier. 5 presets are available, one of which may be customized by the user and loaded into the DSP, thus adapting the speaker's acoustic response to the user's personal taste.

The Internal DSP controller also provides an auxiliary output that may be used to drive an external subwoofer, be it equipped with internal filters like those in the Montarbo product line, or not.

The presets can be modified by means of the Montarbo proprietary software program RAConLSTM, supplied with the LD2.4 USB interface (optional device). The remote control allows: programming and storage of one preset in the DSP and the creation of an unlimited library of personalized settings in the PC; adjustment of the frequency response by means of a 10 filter "fully parametric" equalizer; adjustment of the delay time and of the output level of each speaker system; monitoring of the power amplifier's condition; selection of the type of subwoofer used.

#### FEATURES

- 2 class-D amplifiers (with switching-mode power supplies) that can supply a total of 650 Watts EIAJ (500 W for the LF drivers, 150 W for the HF).
- 133 dB max SPL.
- 15" woofer with 3" voice coil, featuring an external neodymium magnet.
- HF driver with a 1.4" throat and a 2.4" voice coil, featuring a neodymium magnet and titanium diaphragm.
- Wide dispersion (70° H x 50° V), cast aluminum, wave-guide horn.
- Montarbo 56 bit DSP, 180 MHz, 24 bit converters.
- Processed auxiliary output allows to drive an external subwoofer.
- 5 presets one of which may be customized and loaded into the DSP.
- Presets remote control and customization by means of the proprietary software program RAConLSTM™ and the optional LD2.4 USB interface.
- With a single LD2.4 USB interface it is possible to operate up to 10 speaker systems of the SPOT, WIDE and FULL series.
- Birch plywood cabinet, finished with anti-abrasion paint.

- Adjustable feet for use as variable-angle stage monitor; 10 threaded studs (M10) for safe and simple suspension; adapter for a supporting pole; 3 stylish and ergonomic handles.

#### APPLICATIONS

- Main sound system in clubs, small theatres and small open spaces.
- High quality monitoring system.
- Fixed and semi-permanent installations.
- Front-fill and side-fill reinforcement, for stage monitoring, for speech reinforcement, for conventions or conferences.
- The wide dispersion allows for uniform coverage of the audience, even when using a single system per side (FOH).

#### ACCESSORIES

- LD2.4 USB interface supplied with Montarbo proprietary software program RAConLSTM™.
- CV-W153 protection cover.



**SYSTEM'S ARCHITECTURE**

WIDE153 is a full-range bi-amplified system; the transducers employed are one 15" woofer, featuring a 3" voice coil and a powerful, external neodymium magnet; one HF driver with a 1.4" throat and a 2.4" voice coil, featuring a neodymium magnet and titanium diaphragm, loaded by a high directivity (70° H x 50° V) wave-guide horn, made of cast aluminum in order to obtain a 30% reduction of the power compression effect. WIDE 153 incorporates all the electronics needed to process and power the whole system. It includes two class-D amplifiers (with switching-mode power supplies) that can supply a total of 650 Watts EIAJ (500 W for the LF drivers, 150 W for the HF). The crossover frequency is 1200Hz. Operating frequency range is 50Hz to 20KHz and maximum SPL is 133 dB. Coverage is 70-degree horizontal x 50-degree vertical.

The controls and connection panel includes:

- Balanced, line level INPUT (1), it may be fed by balanced or unbalanced sources and it must be connected to the mixer output. It is a 3-pin female XLR connector.
- Input LINK connector (2). It is wired in parallel to the input connector and it makes possible to send the input signal to other equipment (usually to other self-powered speaker systems).
- SUB OUT socket (3) for driving an external active sub-woofer. By selecting the suitable preset the internal DSP may be configured to drive a subwoofer with or without an internal crossover filter. In the first case the output is a wide-band signal, in the second case the output is band-limited and suitable for most active sub-woofers. It is a balanced 3-pin male XLR connector.
- Master volume control (4) that adjusts the system's volume (and the volume of the external subwoofer, if connected).
- DSP section (5) includes: 4 status Led indicators; 5 active Preset Led indicators; UP and DOWN pushbuttons which allow for preset selection; 'Sub 1' and 'Sub 2' Leds that indicate that the SUB OUT output is active and what type of sub-woofer drive signal has been selected.
- RJ45 sockets of the two DATA ports (6) for connection to the Montarbo USBNet control network: a Montarbo LD 2.4 USBNet interface and/or another active speaker of the FULL, SPOT and WIDE series.
- Mains supply inlet socket with type A PowerCon® (blue) (7) connector which guarantees a reliable, vibration-proof contact.
- Type B (gray) PowerCon® connector (8) allows to link other devices to the mains power.
- Mains ON/OFF switch (9).

WIDE153 is equipped with adjustable feet that enable it to be used as a variable-angle stage monitors, 10 threaded studs (M10) for safe and simple suspension and an adapter for a supporting pole. The cabinet built from birch plywood and finished with a special paint providing increased protection and resistance to abrasion, even with intensive, use features a steel protection grille with external foam and three stylish handles made of a special technical elastomer material which ensure a soft and convenient grip. Dimensions are 436mm wide x 730mm high x 395 mm deep. Weight is 29 kg.



WIDE153 Frequency Response  
RED: PRESET1 - MAGENTA: PRESET2 - BLUE: PRESET3 - GREEN: PRESET4

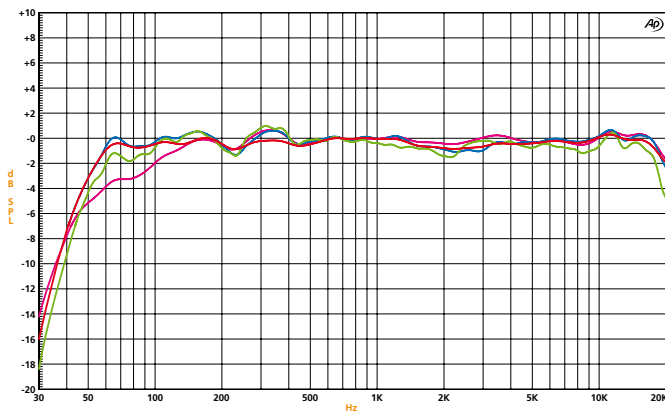

### TECHNICAL SPECIFICATIONS

Enclosure	2-way bass-reflex
Frequency response	50 - 20.000 Hz
Sensitivity	107 dB SPL @ 1W/1m
SPL max.	133 dB
Total Power	650 W EIAJ
<b>• Components</b>	
LF	Custom designed to Montarbo specifications
HF	15" woofer (3" voice coil) with external neodymium magnet compression driver (1.4" throat, 2.4" voice coil) with neodymium magnet and titanium diaphragm high directivity (70° H x 50° V) wave guide horn
<b>• Electronic cross-over</b>	
	1200 Hz
<b>• Built-in amplifier</b>	
Total Output Power	2 class D power units 650 W EIAJ
LF	500 W
HF	150 W
Input sensitivity	0 dBu (775mV)
<b>• Built-in DSP</b>	
Processing	Montarbo 56 bit/180 MHz
Conversion	24 bit
ADC	112 dB
DAC	113 dB
Management functions	Filtering, EQ, delay, limiting, diagnostic 5 presets, 1 of which is custom-programmable Remote control by PC by means of LD2.4 USB interface (optional device)

- **Connections and controls** Balanced XLR connectors for input, link and processed output for driving external subwoofer  
RJ45 DATA connectors for the connection to a PC (Montarbo net)  
PowerCon® for mains power supply (input + link)  
Volume control  
Status Led indicators (signal, clipping, thermal warning, protection)  
Active preset LED indicators

### PHYSICAL SPECIFICATIONS

- **Construction** Birch plywood, anti-abrasion paint  
Steel protection grille with external foam
- **Features** 2 adjustable feet that enable the use as variable-angle stage monitors  
10 threaded studs (M10) for safe and simple suspension  
Adapter for a supporting pole  
3 transport handles made of a special technical elastomer material
- **Dimensions / Weight** W 436 x H 730 x D 395 mm / 29 kg

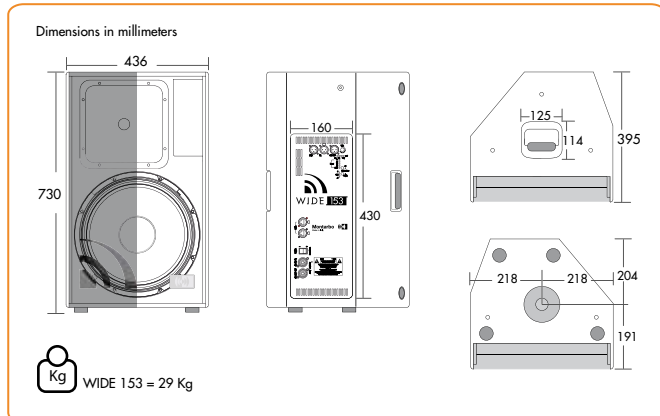

## LD24 USB INTERFACE

This compact, USB-powered interface allows to control and monitor up to 10 systems, using a single USB port of the controlling computer.

Data connection is provided by a single RJ45 connector – a single CAT5 cable is run up to 100 m to the first system and further systems are connected in series.

The network connection between the LD2.4 and the systems is through a standard RS485FD physical interface using Montarbo's proprietary protocol.



### TECHNICAL SPECIFICATIONS

• Dimensions	W 73 x H 45 x D 22 mm
• Interfaces	1 x USB-B 1 x RJ45
• Cable length	100 m (CAT5)
• Maximum network size	10 SPOT, WIDE and FULL speaker system, in any combination.

LD2.4 is supplied with one USB type AB cable and one CD with RAConLS software.

