

active subwoofer

215SA



215SA

800 W continuous
1000 W peak

processor controlled active subwoofer with built-in STEREO electronic cross-over

The 215SA active subwoofer was designed to extend the low frequency response of the W20A system. But at the very first test, it proved to be the perfect companion for loudspeakers of any make and model.

The two 15" units of the 215SA combine performance with significant space savings, a key feature to many pro users.

The cabinet is built with birch multiply, as are the many internal bracings designed to magnify stiffness and rigidity of the box. Truly performing, absolutely easy to operate, the 215SA is built to last show after show, year after year.

As you've come to expect from Montarbo products, anyway.

Montarbo



215SA

ENGLISH Like many Montarbo products, the 215SA comes packed with a full electronic system inside, factory wired and exactly tuned for maximum ease of operation.

The stereo cross-over divides the signal and sends it to the subwoofer amp and the main PA outputs. The MosFet power amp delivers 800 watts through our unique processor, which protects both the speakers and the sonic integrity of the system. Adding the 215SA to the W20A, or to any other system, is as simple as plugging a guitar into its amp.

- The bass reflex enclosure, constructed from birch multiply, is equipped with **two** custom designed 15" high efficiency woofers.
- The built-in class AB dedicated MosFet power amplifier (800 W continuous / 1000 W peak) is controlled by a **24dB/oct STEREO electronic cross-over** and a sophisticated **processor** optimizing the linearity of the frequency response as well as the working performance of the system.
- The connection panel is fitted with:
 - unbalanced XLRs for the stereo output,
 - balanced XLRs for the stereo input and for the 'link' output (allowing parallel connection of other systems),
 - Flat / X-Over selector allowing the output to carry a full-range signal (flat) or the upper audio range only,
 - input level control,
 - ground-lift switch.
- Components and construction are in line with the highest professional standards to provide maximum reliability.



- Speaker stand adaptor
- Stereo electronic crossover
- Transport handle
- High efficiency custom loudspeakers.
- Processor controlled Mosfet power amplifier (class AB)
- Control and connection panel

ITALIANO Come è tradizione Montarbo, il subwoofer attivo 215SA contiene tutto il necessario per l'abbinamento ai sistemi più diversi, già connesso e tarato. Il crossover elettronico stereo 'smista' il segnale destinato al subwoofer dal segnale per gli altoparlanti principali. Il finale di potenza a MosFet eroga la potenza di 800W ai due woofer tramite il processore di controllo, che 'vigila' sui picchi più pericolosi e mantiene stabile il sistema a qualsiasi potenza. Collegare il 215SA ad un qualsiasi impianto esistente è facile come collegare la chitarra all'amplificatore.

- La cassa bass-reflex, costruita in multistrato di betulla, utilizza **due** woofer da 15" costruiti su nostre specifiche.
- L'amplificatore a MosFet, in classe AB, incorporato (800 W continui / 1000 W di picco) è controllato da un **crossover elettronico STEREO a 24dB/oct** e da un sofisticato **processore** che ottimizza la linearità della risposta in frequenza ed il rendimento del sistema.
- Il pannello di controllo dispone di:
 - prese XLR sbilanciate per l'uscita stereo,
 - prese XLR bilanciate per l'ingresso stereo e per il collegamento in parallelo di più sistemi (link),
 - selettore Flat / X-Over che consente di inviare all'uscita il segnale a larga banda (flat) o solo la gamma alta,
 - controllo livello ingresso,
 - ground-lift.
- I materiali e la costruzione rispettano i più alti standard professionali per assicurare la massima affidabilità.

DEUTSCH Der Tradition Montarbos entsprechend, enthält der 215SA alles Notwendige für die Verwendung mit den verschiedensten Systemen, fertig angeschlossen und eingestellt. Die Signale der Satelliten werden von der elektronischen StereoFrequenzweiche für die Satelliten 'sortiert'. Die MosFet-Endstufe liefert 800W über den Prozessor an die beiden Tieftöner. Der Prozessor 'überwacht' dabei gefährliche Stromspitzen und hält das System bei jeder Leistung stabil. Der Anschluß des 215SA an eine beliebige Anlage ist so einfach, wie eine Gitarre an einen Verstärker anzuschließen!

- Die Bassreflex-Box, aus mehrfach phenol-verleimtem Birkenholz, ist mit **zwei 15"** spezial gefertigten Hochleistungs-Tieftöner bestückt.
- Der eingebaute MosFet Verstärker in der Klasse AB (800 W Dauerleistung / 1000 W Spitzenleistung) besitzt eine **24dB/Okt. elektronische STEREO Frequenzweiche** und einen hochentwickelten **Prozessor**, der die Linearität des Frequenzganges und die Leistung des Systems optimiert .
- Das Anschlußfeld verfügt über:
 - unsymmetrische XLR Buchsen für den Stereoausgang,
 - symmetrische XLR Buchsen für den Stereoeingang und für den Parallelanschluß mehrerer Systeme (link),
 - Flat / X-Over -Schalter (es ermöglicht dem Ausgang entweder ein breitbandiges Signal - flat - oder nur den oberen Frequenzbereich zu senden),
 - Kontrolle des Eingangspegels,
 - Erdungsschalter.
- Bauteile und Konstruktion erfüllen höchste professionelle Standards und garantieren maximale Zuverlässigkeit.

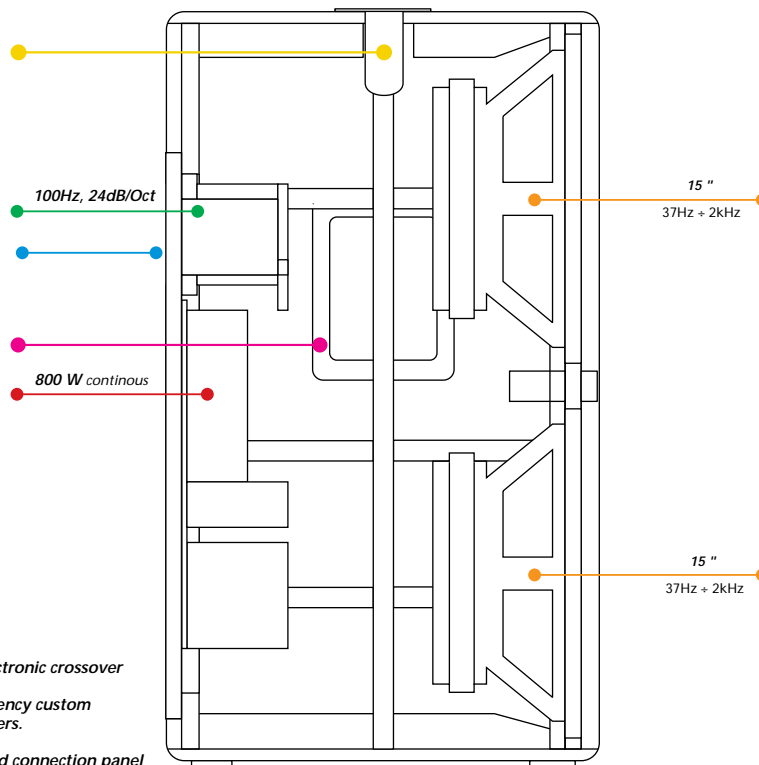

active subwoofer

Montarbo

ESPAÑOL

Seguindo la tradición de Montarbo, el subwoofer activo 215SA contiene todo lo necesario para combinarse con los sistemas más diversos, ya conectado y calibrado. El crossover electrónico estéreo separa la señal destinada al subwoofer de la que va a los altavoces principales. El final de potencia con MosFet suministra 800 W a los dos woofers a través del procesador de control, que vigila los picos más peligrosos y mantiene el sistema estable a cualquier potencia. Conectar el 215SA a cualquier equipo existente es tan fácil como conectar la guitarra al amplificador.

- La caja bass-reflex, construida en multicapa de abedul utiliza **dos woofers de 15"** de alta eficiencia realizados según nuestras propias especificaciones.
- El amplificador de potencia a MosFet en clase AB (**800 W** continuos / **1000 W** de pico) es controlado por un **crossover electrónico estéreo de 24dB/oct.** y un sofisticado **procesador** que optimiza la dinámica y la respuesta en frecuencia y garantiza las máximas prestaciones, acreciendo así la fiabilidad del sistema.
- El panel de controles dispone de:
 - tomas XLR desbalanceadas para la salida estéreo
 - tomas XLR balanceadas para la entrada estéreo y el 'link' (para conectar otros sistemas en paralelo)
 - selector Flat / X-Over (permite enviar a la salida la señal de banda ancha, flat, o solo la gama alta)
 - control nivel entrada,
 - ground-lift.
- Los materiales y la construcción respetan los más elevados estándares profesionales para asegurar la máxima fiabilidad.

FRANÇAIS

Comme l'exige la tradition Montarbo, le subwoofer actif 215SA possède tout ce qui est nécessaire, pré-monté et réglé pour une parfaite adaptation aux systèmes les plus divers. Le crossover électronique stéréo effectue l'aiguillage du signal destiné au subwoofer, le séparant de celui des haut-parleurs principaux. L'amplificateur MosFet de 800W alimente les deux woofers par le biais du processeur de contrôle qui surveille les crêtes les plus dangereuses et maintient la stabilité du système, quelle que soit la puissance. Relier le 215SA à n'importe quelle installation existante, il est aussi simple que connecter une guitare à son amplificateur.

- Le baffle bass-reflex, en multipli de bouleau, est équipé de **deux woofers de 15"** à haute efficacité construits selon nos spécifications.
- L'amplificateur de puissance à MosFet incorporé (**800 W** continue / **1000 W** en crête) est contrôlé par un **cross-over électronique STÉRÉO de 24dB/oct.** et par un **processeur** qui optimise la linéarité de la courbe de réponse et le rendement du système.
- Le panneau de contrôle est équipé de:
 - prises XLR asymétriques pour la sortie stéréo,
 - prises XLR symétriques pour l'entrée stéréo et pour la connexion de plusieurs systèmes en parallèle (link),
 - sélecteur Flat/X-over (permet d'envoyer un signal large bande ou seulement les fréquences au dessus),
 - contrôle du niveau d'entrée,
 - ground-lift.
- Les matériels et la construction respectent les standard professionnels les plus élevés pour assurer une fiabilité maximum.

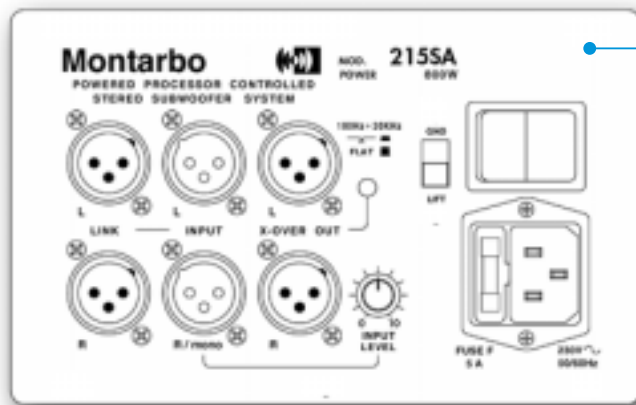
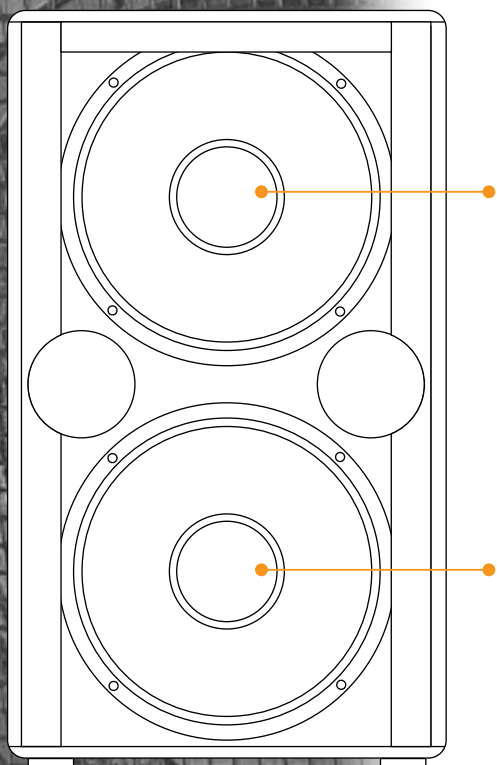

215SA

active sub

Designed and manufactured in Italy by:

Montarbo



Elettronica Montarbo srl
 40057 Cadriano Granarolo Emilia Bologna (Italy)
 phone: +39 051 766437 fax: +39 051 765226
 e-mail: mail@montarbo.com internet: www.montarbo.com

Specifications and features are subject to change without prior notice.
 The contents of this publication may not be reproduced in any manner without
 prior written permission of Elettronica Montarbo srl. All rights reserved.

You can stack two 215SA subs one on top the other with total safety (thanks to male/female stop blocks), or place a full-range system on a pole that locks into the 215SA. Easy, fast, and reliable, whatever the choice.

215SA and W20A



SPECIFICATIONS

SPECIFICATIONS

- **Enclosure:** bass-reflex
- Frequency response: 37Hz ± 100Hz
- Sensitivity (1W, 1m): 102dB
- Max SPL: 130dB (half space)
- Components : 2 x 15" high efficiency custom designed woofers
- Electronic stereo X-over: 100Hz / 24dB oct
- Construction: Multiply birch Polyurethane resin
- **Amplifier:** MosFet, class AB, processor controlled,
- Max. output power: 800 W continuous (8 Ω / 0,1% THD) 1000 W peak
- Connections:
 - X-over stereo input: balanced XLRs
 - 'link' output (parallel): balanced XLRs
 - X-over stereo output: unbalanced XLRs
- **Dimensions (WxHxD):** 50,5 x 87,5 x 49,5 cm
- **Weight:** 59 kg

COMBINATIONS

Mixer + 1 215SA + 2 W20A

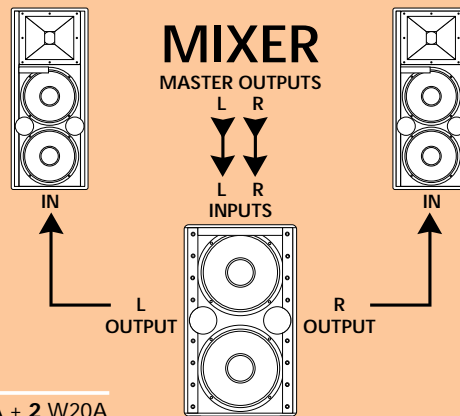

Mixer + 2 215SA + 2 W20A

