

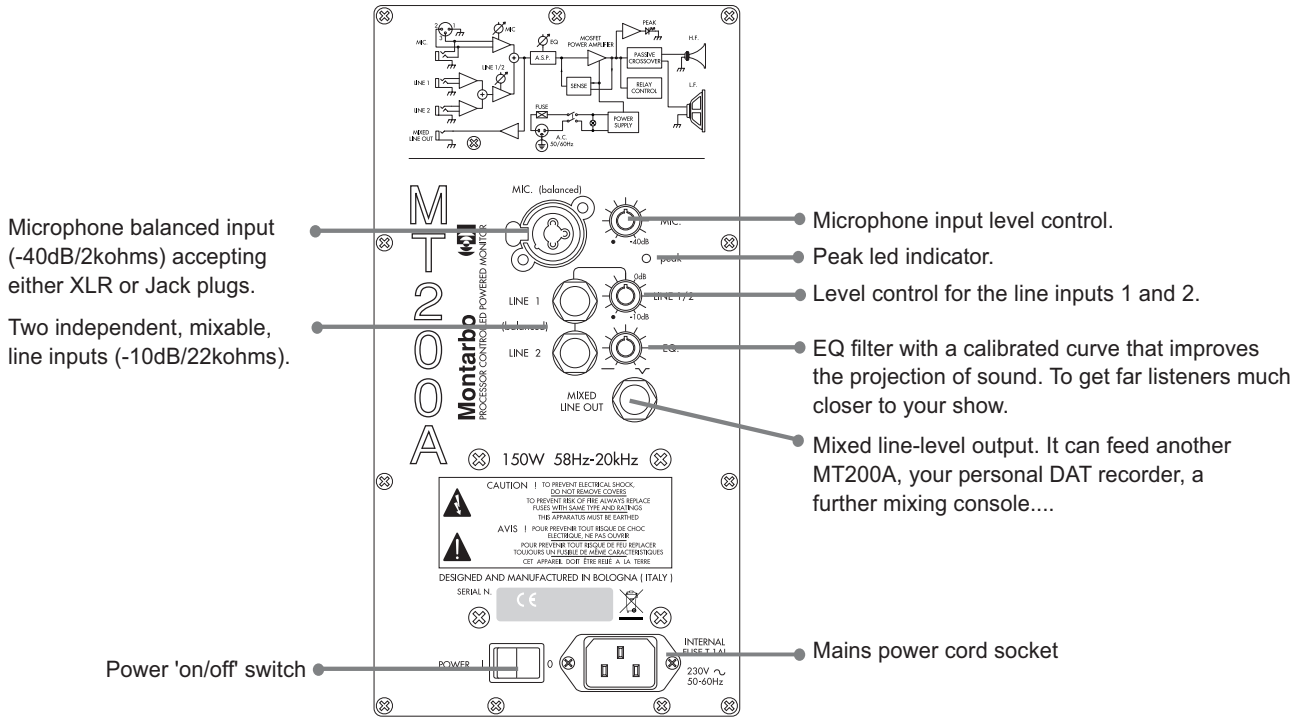

MT200A

active, processor controlled, 2-way system



Front view

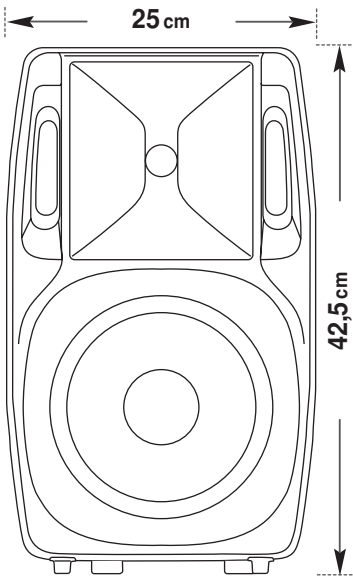

Rear view

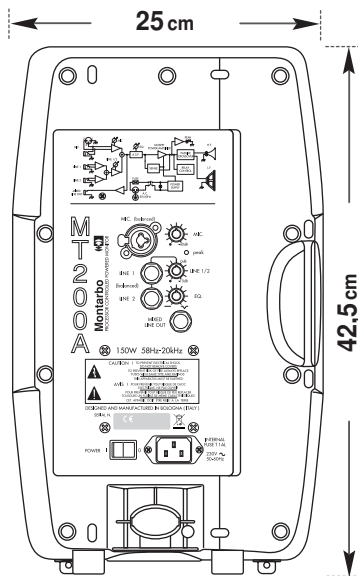

Side view

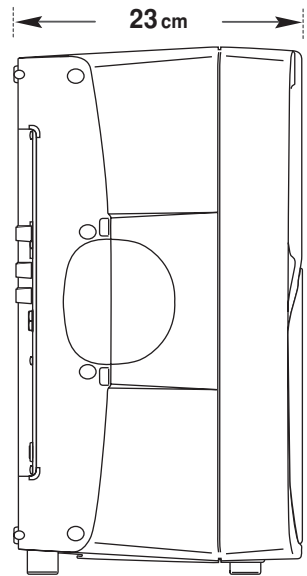

Bottom view

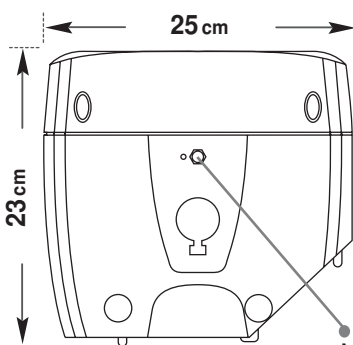

Mounting hardware: threaded insert 8 M

Top view

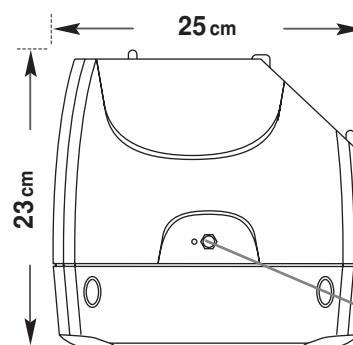

Mounting hardware: threaded insert 8 M